



Tulare Public Cemetery District



900 East Kern Avenue Tulare, CA 93274
Phone (559) 686-5544 Fax (559) 686-7484

BOARD AGENDA

Special Board Meeting
January 5, 2022
3:30 P.M.

PRELIMINARIES:

- 1.1 Call to Order
- 1.2 Roll Call
- 1.3 Public Comments (Three (3) Minutes Per Person)
- 1.4 Trustee Comments (Three (3) Minutes Per Person)

NOTICE TO THE PUBLIC PUBLIC COMMENT PERIOD

AT THIS TIME, MEMBERS OF THE PUBLIC MAY COMMENT ON ANY ITEM THAT IS NOT ON THE AGENDA THAT IS WITHIN THE JURISDICTION OF THE BOARD. Under state law, matters presented under this item cannot be discussed or acted upon by the board at this time. For items appearing on the agenda, the public is invited to make comments at the time the item comes up for board consideration. Any person addressing the board will be limited to a maximum of three (3) minutes so that all interested parties have an opportunity to speak

OPEN SESSION – AGENDA ITEMS: (All items are subject to discussion and possible action by the Board of Trustees.)

- 2.1 Interment count for year
- 2.2 Expansion of Kern Cemetery (Oleander Lane)
- 2.3 California Association of Public Cemeteries
- 2.4 Policy addressing capacity of graves
- 2.5 Reversal charge from our accountant
- 2.6 ERTC Credit

ADJOURNMENT:

OPEN SESSION AGENDA ITEMS NOTICE TO THE PUBLIC

ALL WRITINGS, MATERIALS AND INFORMATION PROVIDED TO THE BOARD FOR THEIR CONSIDERATION RELATING TO ANY OPEN SESSION AGENDA ITEMS OF THE MEETING ARE AVAILABLE FOR PUBLIC INSPECTION DURING NORMAL BUSINESS HOURS MONDAY THROUGH FRIDAY 8:00 AM – 5:00 PM AT THE ADMINISTRATION OFFICE OF THE DISTRICT LOCATED AT 900 E. KERN AVE., TULARE, CA 93274

IN COMPLIANCE WITH THE AMERICANS WITH DISABILITIES ACT, IF YOU SHOULD NEED SPECIAL ASSISTANCE TO PARTICIPATE IN THIS MEETING, PLEASE CONTACT THE BOARD OFFICE AT (559) 686-5544 FORTY-EIGHT (48) HOURS PRIOR TO THIS MEETING.

Rules of Decorum

- Meetings of the Tulare Cemetery District shall be conducted in an orderly manner to ensure that the public has a full opportunity to be heard and that the deliberative process of the Trustees is retained at all times.
- No person in the audience at a District meeting shall engage in disorderly, boisterous conduct or other acts which disturb, disrupt or otherwise impede the orderly conduct of any District meeting.
- The Chair shall request that a person who is breaching the rules of decorum be orderly and silent. If, after receiving a warning from the Chair, a person persists in disturbing the meeting, the Chair shall order him or her, to leave the District meeting.
- If such person does not remove himself or herself, the Penal Code provides that every person who, without authority of law, willfully disturbs or breaks up any meeting, not unlawful in its character, is guilty of a misdemeanor.

Addressing the Cemetery Board

- No person shall address the Trustees without first being recognized by the Chair.
- Each person shall confine his or her remarks to the agenda item.
- Each person shall limit his or her remarks for business items or oral communications to three minutes, with a total of 15 minutes allotted for the Public Comment Period unless further time is granted by the Chair.
- All remarks shall be addressed to the Trustees as a whole and not to any single member thereof, unless in response to a question from such member.
- No question may be asked of the Trustees without permission of the Chair.

Trustee Conduct

- The Tulare Public Cemetery Trustees agree to disagree.
- The Tulare Public Cemetery Trustees when desiring to speak shall address the Chair and confine their remarks to the questions under debate.
- The Tulare Public Cemetery Trustees will use respectful language, will not shout nor use aggressive behavior when communicating ideas, beliefs or comments.
- The Tulare Public Cemetery Trustees will not allow personal attacks on staff, each other, or the public.
- The Tulare Public Cemetery Trustees will not condone issues brought before the board that warrant public review without allowing the staff to review the situation and/or permission to add to the board agenda. Issues that warrant review, discussion and/or consideration of the legislative body shall be presented at an open and public meeting in a courteous and professional manner.
- The Tulare Public Cemetery Trustees will not condone grandstanding.
- The Tulare Public Cemetery Trustees will not belabor issues that have either been resolved or tabled to ensure continued productive discussions and decisions.
- The Tulare Public Cemetery Trustees will be proactive in addressing disagreements with fellow members or staff by directly addressing concerns with that member through meaningful and respectful dialogue.

TULARE PUBLIC CEMETERY DISTRICT
Grand Yearly Totals 2018-2022 Interments and Entombments

KERN							
Year	Body Burials	Niches	Cremation in Casket	Cremation Burials	Baby Burials	Disinterments	TOTAL
2018	101	12	0	59	2	0	174
2019	90	19	0	52	1	0	162
2020	105	25	0	52	1	0	183
2021	122	26	1	67	0	0	216
2022	0	0	0	0	0	0	0

Pre-Needs			
Burial	Niche	1/2 Grave	Total
0	0	0	0
0	0	0	0
0	0	0	0
5	9	7	21
0	0	0	0

NORTH							
Year	Body Burials	Niches	Cremation in Casket	Cremation Burials	Baby Burials	Disinterments	TOTAL
2018	117	0	0	5	2	0	124
2019	114	0	0	19	2	0	135
2020	166	0	0	23	6	1	196
2021	203	0	0	39	2	1	245
2022	0	0	0	0	0	0	0

Pre-Needs			
Burial	Niche	1/2 Grave	Total
0	0	0	0
0	0	0	0
0	0	0	0
111	0	5	116
0	0	0	0

TOTAL BOTH							
Year	Body Burials	Niches	Cremation in Casket	Cremation Burials	Baby Burials	Disinterments	TOTAL
2018	218	12	0	64	4	0	298
2019	204	19	0	71	3	0	297
2020	271	25	0	75	7	1	379
2021	325	26	1	106	2	1	461
2022	0	0	0	0	0	0	0

Pre-Needs Total			
Burial	Niche	1/2 Grave	Total
0	0	0	0
0	0	0	0
0	0	0	0
116	9	12	137
0	0	0	0

TULARE PUBLIC CEMETERY DISTRICT
January 2018-2022 Interments and Entombments

KERN							
Year	Body Burials	Niches	Cremation in Casket	Cremation Burials	Baby Burials	Disinterments	TOTAL
2018	9	1	0	4	1	0	15
2019	11	0	0	6	0	0	17
2020	14	0	0	5	0	0	19
2021	14	4	0	7	0	0	25
2022	0	0	0	0	0	0	0

Pre-Needs				
Burial	Niche	1/2 Grave	Total	
0	0	0	0	
0	0	0	0	
0	0	0	0	
0	3	1	4	
0	0	0	0	

NORTH							
Year	Body Burials	Niches	Cremation in Casket	Cremation Burials	Baby Burials	Disinterments	TOTAL
2018	11	0	0	0	1	0	12
2019	7	0	0	2	0	0	9
2020	19	0	0	1	0	0	20
2021	23	0	0	4	1	1	29
2022	0	0	0	0	0	0	0

Pre-Needs				
Burial	Niche	1/2 Grave	Total	
0	0	0	0	
0	0	0	0	
0	0	0	0	
11	0	0	11	
0	0	0	0	

TOTAL BOTH							
Year	Body Burials	Niches	Cremation in Casket	Cremation Burials	Baby Burials	Disinterments	TOTAL
2018	20	1	0	4	2	0	27
2019	18	0	0	8	0	0	26
2020	33	0	0	6	0	0	39
2021	37	4	0	11	1	1	54
2022	0	0	0	0	0	0	0

Pre-Needs Total				
Burial	Niche	1/2 Grave	Total	
0	0	0	0	
0	0	0	0	
0	0	0	0	
11	3	1	15	
0	0	0	0	

TULARE PUBLIC CEMETERY DISTRICT
February 2018-2022 Interments and Entombments

KERN							
Year	Body Burials	Niches	Cremation in Casket	Cremation Burials	Baby Burials	Disinterments	TOTAL
2018	8	0	0	6	0	0	14
2019	8	1	0	5	1	0	15
2020	7	1	0	5	0	0	13
2021	13	2	0	4	0	0	19
2022	0	0	0	0	0	0	0

Pre-Needs				
Burial	Niche	1/2 Grave	Total	
0	0	0	0	0
0	0	0	0	0
0	0	0	0	0
0	0	0	0	0
0	0	0	0	0

NORTH							
Year	Body Burials	Niches	Cremation in Casket	Cremation Burials	Baby Burials	Disinterments	TOTAL
2018	10	0	0	1	0	0	11
2019	6	0	0	3	0	0	9
2020	13	0	0	1	0	0	14
2021	26	0	0	6	0	0	32
2022	0	0	0	0	0	0	0

Pre-Needs				
Burial	Niche	1/2 Grave	Total	
0	0	0	0	0
0	0	0	0	0
0	0	0	0	0
4	0	1	5	5
0	0	0	0	0

TOTAL BOTH							
Year	Body Burials	Niches	Cremation in Casket	Cremation Burials	Baby Burials	Disinterments	TOTAL
2018	18	0	0	7	0	0	25
2019	14	1	0	8	1	0	24
2020	20	1	0	6	0	0	27
2021	39	2	0	10	0	0	51
2022	0	0	0	0	0	0	0

Pre-Needs Total				
Burial	Niche	1/2 Grave	Total	
0	0	0	0	0
0	0	0	0	0
0	0	0	0	0
4	0	1	5	5
0	0	0	0	0

TULARE PUBLIC CEMETERY DISTRICT
March 2018-2022 Interments and Entombments

KERN							
Year	Body Burials	Niches	Cremation in Casket	Cremation Burials	Baby Burials	Disinterments	TOTAL
2018	14	0	0	7	0	0	21
2019	8	0	0	4	0	0	12
2020	7	3	0	4	0	0	14
2021	6	1	0	8	0	0	15
2022	0	0	0	0	0	0	0

Pre-Needs				
Burial	Niche	1/2 Grave	Total	
0	0	0	0	
0	0	0	0	
0	0	0	0	
2	0	0	2	
0	0	0	0	

NORTH							
Year	Body Burials	Niches	Cremation in Casket	Cremation Burials	Baby Burials	Disinterments	TOTAL
2018	13	0	0	1	0	0	14
2019	20	0	0	0	0	0	20
2020	16	0	0	1	1	0	18
2021	19	0	0	3	1	0	23
2022	0	0	0	0	0	0	0

Pre-Needs				
Burial	Niche	1/2 Grave	Total	
0	0	0	0	
0	0	0	0	
0	0	0	0	
15	0	0	15	
0	0	0	0	

TOTAL BOTH							
Year	Body Burials	Niches	Cremation in Casket	Cremation Burials	Baby Burials	Disinterments	TOTAL
2018	27	0	0	8	0	0	35
2019	28	0	0	4	0	0	32
2020	23	3	0	5	1	0	32
2021	25	1	0	11	1	0	38
2022	0	0	0	0	0	0	0

Pre-Needs Total				
Burial	Niche	1/2 Grave	Total	
0	0	0	0	
0	0	0	0	
0	0	0	0	
17	0	0	17	
0	0	0	0	

TULARE PUBLIC CEMETERY DISTRICT
April 2018-2022 Interments and Entombments

KERN							
Year	Body Burials	Niches	Cremation in Casket	Cremation Burials	Baby Burials	Disinterments	TOTAL
2018	7	2	0	5	0	0	14
2019	6	3	0	6	0	0	15
2020	6	3	0	2	0	0	11
2021	8	2	0	6	0	0	16
2022	0	0	0	0	0	0	0

Pre-Needs				
Burial	Niche	1/2 Grave	Total	
0	0	0	0	0
0	0	0	0	0
0	0	0	0	0
0	0	1	1	1
0	0	0	0	0

NORTH							
Year	Body Burials	Niches	Cremation in Casket	Cremation Burials	Baby Burials	Disinterments	TOTAL
2018	11	0	0	0	1	0	12
2019	10	0	0	1	0	0	11
2020	9	0	0	3	0	0	12
2021	10	0	0	5	0	0	15
2022	0	0	0	0	0	0	0

Pre-Needs				
Burial	Niche	1/2 Grave	Total	
0	0	0	0	0
0	0	0	0	0
0	0	0	0	0
11	0	0	0	11
0	0	0	0	0

TOTAL BOTH							
Year	Body Burials	Niches	Cremation in Casket	Cremation Burials	Baby Burials	Disinterments	TOTAL
2018	18	2	0	5	1	0	26
2019	16	3	0	7	0	0	26
2020	15	3	0	5	0	0	23
2021	18	2	0	11	0	0	31
2022	0	0	0	0	0	0	0

Pre-Needs Total				
Burial	Niche	1/2 Grave	Total	
0	0	0	0	0
0	0	0	0	0
0	0	0	0	0
11	0	1	1	12
0	0	0	0	0

TULARE PUBLIC CEMETERY DISTRICT
May 2018-2022 Interments and Entombments

KERN							
Year	Body Burials	Niches	Cremation in Casket	Cremation Burials	Baby Burials	Disinterments	TOTAL
2018	12	0	0	3	1	0	16
2019	5	2	0	6	0	0	13
2020	7	1	0	4	0	0	12
2021	10	3	0	5	0	0	18
2022	0	0	0	0	0	0	0

Pre-Needs				
Burial	Niche	1/2 Grave	Total	
0	0	0	0	
0	0	0	0	
0	0	0	0	
0	2	0	2	
0	0	0	0	

NORTH							
Year	Body Burials	Niches	Cremation in Casket	Cremation Burials	Baby Burials	Disinterments	TOTAL
2018	12	0	0	0	0	0	12
2019	7	0	0	1	0	0	8
2020	9	0	0	1	0	0	10
2021	9	0	0	2	0	0	11
2022	0	0	0	0	0	0	0

Pre-Needs				
Burial	Niche	1/2 Grave	Total	
0	0	0	0	
0	0	0	0	
0	0	0	0	
8	0	1	9	
0	0	0	0	

TOTAL BOTH							
Year	Body Burials	Niches	Cremation in Casket	Cremation Burials	Baby Burials	Disinterments	TOTAL
2018	24	0	0	3	1	0	28
2019	12	2	0	7	0	0	21
2020	16	1	0	5	0	0	22
2021	19	3	0	7	0	0	29
2022	0	0	0	0	0	0	0

Pre-Needs Total				
Burial	Niche	1/2 Grave	Total	
0	0	0	0	
0	0	0	0	
0	0	0	0	
8	2	1	11	
0	0	0	0	

TULARE PUBLIC CEMETERY DISTRICT
June 2018-2022 Interments and Entombments

KERN							
Year	Body Burials	Niches	Cremation in Casket	Cremation Burials	Baby Burials	Disinterments	TOTAL
2018	11	4	0	7	0	0	22
2019	6	0	0	2	0	0	8
2020	11	1	0	3	0	0	15
2021	9	3	0	10	0	0	22
2022	0	0	0	0	0	0	0

Pre-Needs				
Burial	Niche	1/2 Grave	Total	
0	0	0	0	0
0	0	0	0	0
0	0	0	0	0
0	1	0	1	1
0	0	0	0	0

NORTH							
Year	Body Burials	Niches	Cremation in Casket	Cremation Burials	Baby Burials	Disinterments	TOTAL
2018	17	0	0	0	0	0	17
2019	5	0	0	2	0	0	7
2020	6	0	0	2	0	1	9
2021	15	0	0	4	0	0	19
2022	0	0	0	0	0	0	0

Pre-Needs				
Burial	Niche	1/2 Grave	Total	
0	0	0	0	0
0	0	0	0	0
0	0	0	0	0
6	0	1	7	7
0	0	0	0	0

TOTAL BOTH							
Year	Body Burials	Niches	Cremation in Casket	Cremation Burials	Baby Burials	Disinterments	TOTAL
2018	28	4	0	7	0	0	39
2019	11	0	0	4	0	0	15
2020	17	1	0	5	0	1	24
2021	24	3	0	14	0	0	41
2022	0	0	0	0	0	0	0

Pre-Needs Total				
Burial	Niche	1/2 Grave	Total	
0	0	0	0	0
0	0	0	0	0
0	0	0	0	0
6	1	1	8	8
0	0	0	0	0

TULARE PUBLIC CEMETERY DISTRICT
July 2018-2022 Interments and Entombments

KERN							
Year	Body Burials	Niches	Cremation in Casket	Cremation Burials	Baby Burials	Disinterments	TOTAL
2018	10	4	0	3	0	0	17
2019	6	1	0	6	0	0	13
2020	6	1	0	3	0	0	10
2021	8	2	0	1	0	0	11
2022	0	0	0	0	0	0	0

Pre-Needs			
Burial	Niche	1/2 Grave	Total
0	0	0	0
0	0	0	0
0	0	0	0
0	0	4	4
0	0	0	0

NORTH							
Year	Body Burials	Niches	Cremation in Casket	Cremation Burials	Baby Burials	Disinterments	TOTAL
2018	8	0	0	0	0	0	8
2019	12	0	0	0	0	0	12
2020	18	0	0	5	1	0	24
2021	15	0	0	0	0	0	15
2022	0	0	0	0	0	0	0

Pre-Needs			
Burial	Niche	1/2 Grave	Total
0	0	0	0
0	0	0	0
0	0	0	0
9	0	1	10
0	0	0	0

TOTAL BOTH							
Year	Body Burials	Niches	Cremation in Casket	Cremation Burials	Baby Burials	Disinterments	TOTAL
2018	18	4	0	3	0	0	25
2019	18	1	0	6	0	0	25
2020	24	1	0	8	1	0	34
2021	23	2	0	1	0	0	26
2022	0	0	0	0	0	0	0

Pre-Needs Total			
Burial	Niche	1/2 Grave	Total
0	0	0	0
0	0	0	0
0	0	0	0
9	0	5	14
0	0	0	0

TULARE PUBLIC CEMETERY DISTRICT
August 2018-2022 Interments and Entombments

KERN							
Year	Body Burials	Niches	Cremation in Casket	Cremation Burials	Baby Burials	Disinterments	TOTAL
2018	5	0	0	7	0	0	12
2019	5	0	0	5	0	0	10
2020	10	3	0	9	0	0	22
2021	11	1	0	7	0	0	19
2022	0	0	0	0	0	0	0

Pre-Needs			
Burial	Niche	1/2 Grave	Total
0	0	0	0
0	0	0	0
0	0	0	0
2	0	1	3
0	0	0	0

NORTH							
Year	Body Burials	Niches	Cremation in Casket	Cremation Burials	Baby Burials	Disinterments	TOTAL
2018	10	0	0	1	0	0	11
2019	6	0	0	1	1	0	8
2020	14	0	0	0	1	0	15
2021	8	0	0	2	0	0	10
2022	0	0	0	0	0	0	0

Pre-Needs			
Burial	Niche	1/2 Grave	Total
0	0	0	0
0	0	0	0
0	0	0	0
13	0	0	13
0	0	0	0

TOTAL BOTH							
Year	Body Burials	Niches	Cremation in Casket	Cremation Burials	Baby Burials	Disinterments	TOTAL
2018	15	0	0	8	0	0	23
2019	11	0	0	6	1	0	18
2020	24	3	0	9	1	0	37
2021	19	1	0	9	0	0	29
2022	0	0	0	0	0	0	0

Pre-Needs Total			
Burial	Niche	1/2 Grave	Total
0	0	0	0
0	0	0	0
0	0	0	0
15	0	1	16
0	0	0	0

TULARE PUBLIC CEMETERY DISTRICT
September 2018-2022 Interments and Entombments

KERN							
Year	Body Burials	Niches	Cremation in Casket	Cremation Burials	Baby Burials	Disinterments	TOTAL
2018	7	0	0	5	0	0	12
2019	7	3	0	1	0	0	11
2020	9	4	0	4	0	0	17
2021	11	3	0	6	0	0	20
2022	0	0	0	0	0	0	0

Pre-Needs				
Burial	Niche	1/2 Grave	Total	
0	0	0	0	0
0	0	0	0	0
0	0	0	0	0
0	0	0	0	0
0	0	0	0	0

NORTH							
Year	Body Burials	Niches	Cremation in Casket	Cremation Burials	Baby Burials	Disinterments	TOTAL
2018	8	0	0	2	0	0	10
2019	13	0	0	1	0	0	14
2020	11	0	0	4	1	0	16
2021	20	0	0	2	0	0	22
2022	0	0	0	0	0	0	0

Pre-Needs				
Burial	Niche	1/2 Grave	Total	
0	0	0	0	0
0	0	0	0	0
0	0	0	0	0
14	0	1	1	15
0	0	0	0	0

TOTAL BOTH							
Year	Body Burials	Niches	Cremation in Casket	Cremation Burials	Baby Burials	Disinterments	TOTAL
2018	15	0	0	7	0	0	22
2019	20	3	0	2	0	0	25
2020	20	4	0	8	1	0	33
2021	31	3	0	8	0	0	42
2022	0	0	0	0	0	0	0

Pre-Needs Total				
Burial	Niche	1/2 Grave	Total	
0	0	0	0	0
0	0	0	0	0
0	0	0	0	0
14	0	1	1	15
0	0	0	0	0

TULARE PUBLIC CEMETERY DISTRICT
October 2018-2022 Interments and Entombments

KERN							
Year	Body Burials	Niches	Cremation in Casket	Cremation Burials	Baby Burials	Disinterments	TOTAL
2018	5	0	0	8	0	0	13
2019	10	2	0	3	0	0	15
2020	6	3	0	8	1	0	18
2021	7	2	1	7	0	0	17
2022	0	0	0	0	0	0	0

Pre-Needs				
Burial	Niche	1/2 Grave	Total	
0	0	0	0	
0	0	0	0	
0	0	0	0	
1	2	0	3	
0	0	0	0	

NORTH							
Year	Body Burials	Niches	Cremation in Casket	Cremation Burials	Baby Burials	Disinterments	TOTAL
2018	7	0	0	0	0	0	7
2019	9	0	0	5	0	0	14
2020	12	0	0	0	1	0	13
2021	25	0	0	2	0	0	27
2022	0	0	0	0	0	0	0

Pre-Needs				
Burial	Niche	1/2 Grave	Total	
0	0	0	0	
0	0	0	0	
0	0	0	0	
7	0	0	7	
0	0	0	0	

TOTAL BOTH							
Year	Body Burials	Niches	Cremation in Casket	Cremation Burials	Baby Burials	Disinterments	TOTAL
2018	12	0	0	8	0	0	20
2019	19	2	0	8	0	0	29
2020	18	3	0	8	2	0	31
2021	32	2	1	9	0	0	44
2022	0	0	0	0	0	0	0

Pre-Needs Total				
Burial	Niche	1/2 Grave	Total	
0	0	0	0	
0	0	0	0	
0	0	0	0	
8	2	0	10	
0	0	0	0	

TULARE PUBLIC CEMETERY DISTRICT
November 2018-2022 Interments and Entombments

KERN							
Year	Body Burials	Niches	Cremation In Casket	Cremation Burials	Baby Burials	Disinterments	TOTAL
2018	7	1	0	2	0	0	10
2019	7	3	0	8	0	0	18
2020	11	2	0	4	0	0	17
2021	13	2	0	4	0	0	19
2022	0	0	0	0	0	0	0

Pre-Needs				
Burial	Niche	1/2 Grave	Total	
0	0	0	0	0
0	0	0	0	0
0	0	0	0	0
0	1	0	1	1
0	0	0	0	0

NORTH							
Year	Body Burials	Niches	Cremation In Casket	Cremation Burials	Baby Burials	Disinterments	TOTAL
2018	6	0	0	0	0	0	6
2019	10	0	0	2	0	0	12
2020	16	0	0	4	1	0	21
2021	13	0	0	7	0	0	20
2022	0	0	0	0	0	0	0

Pre-Needs				
Burial	Niche	1/2 Grave	Total	
0	0	0	0	0
0	0	0	0	0
0	0	0	0	0
4	0	0	4	4
0	0	0	0	0

TOTAL BOTH							
Year	Body Burials	Niches	Cremation In Casket	Cremation Burials	Baby Burials	Disinterments	TOTAL
2018	13	1	0	2	0	0	16
2019	17	3	0	10	0	0	30
2020	27	2	0	8	1	0	38
2021	26	2	0	11	0	0	39
2022	0	0	0	0	0	0	0

Pre-Needs Total				
Burial	Niche	1/2 Grave	Total	
0	0	0	0	0
0	0	0	0	0
0	0	0	0	0
4	1	0	5	5
0	0	0	0	0

TULARE PUBLIC CEMETERY DISTRICT
December 2018-2022 Interments and Entombments

KERN							
Year	Body Burials	Niches	Cremation In Casket	Cremation Burials	Baby Burials	Disinterments	TOTAL
2018	6	0	0	2	0	0	8
2019	11	4	0	0	0	0	15
2020	11	3	0	1	0	0	15
2021	12	1	0	2	0	0	15
2022	0	0	0	0	0	0	0

Pre-Needs				
Burial	Niche	1/2 Grave	Total	
0	0	0	0	0
0	0	0	0	0
0	0	0	0	0
0	0	0	0	0
0	0	0	0	0

NORTH							
Year	Body Burials	Niches	Cremation In Casket	Cremation Burials	Baby Burials	Disinterments	TOTAL
2018	4	0	0	0	0	0	4
2019	9	0	0	1	1	0	11
2020	23	0	0	1	0	0	24
2021	20	0	0	2	0	0	22
2022	0	0	0	0	0	0	0

Pre-Needs				
Burial	Niche	1/2 Grave	Total	
0	0	0	0	0
0	0	0	0	0
0	0	0	0	0
9	0	0	9	9
0	0	0	0	0

TOTAL BOTH							
Year	Body Burials	Niches	Cremation In Casket	Cremation Burials	Baby Burials	Disinterments	TOTAL
2018	10	0	0	2	0	0	12
2019	20	4	0	1	1	0	26
2020	34	3	0	2	0	0	39
2021	32	1	0	4	0	0	37
2022	0	0	0	0	0	0	0

Pre-Needs Total				
Burial	Niche	1/2 Grave	Total	
0	0	0	0	0
0	0	0	0	0
0	0	0	0	0
9	0	0	9	9
0	0	0	0	0

“Oleander Lane Memorials”

200 - Tall Stone Plots at Kern Cemetery

(Space 8' x 10')

(890 feet long, minus 11 benches space, minus pump cage, minus tree = 800 feet available space for plots / 4 feet = 200 plots)

200 Tall Stones X \$7500 = \$1,500,00

Opening & Closing based on 2 per plot – 2 x \$2000 = \$4000
\$4000 x 200 plots = \$800,000

Installation Fee for Liner based on 2 per plot – 2 x \$263 = \$526
\$526 x 200 = \$105,200

Endowment based on 2 per plot – 2 x \$393 = \$786
\$786 x 200 plots = \$157,200

Administration Fee based on 2 per plot – 2 x \$300 = \$600
\$600 x 200 plots = \$120,000

Total \$2,682,400

Possible Additional Income

After last casket internment is in, a bench can be placed on each of the 200 plots

200 x \$2500 = \$500,000

“Oleander Lane Memorials”

COST FOR COLUMBARIUM

$$11 \times 32 = 352$$

TOTAL = 352 Niche Vaults

Cost \$80,993 \$230.09 per Vault

SALES FOR COLUMBARIUM

Can hold up to 2 Urn (of course based on Urn size)

Niche Vaults 352 x **\$1304.33**

(Average Vault Price w/out Endowment or Admin Fee)

$$= \$459,124.16$$

\$80,993

\$378,131.16

(other expense not accounted for is concrete under niches)

Endowment based on only 1 Entombment

$$352 \times \$172 = \$60,544 \quad (\text{if 2 per } \$121,088)$$

Administration Fee based on only 1 Entombment

$$352 \times \$300 = \$105,600 \quad (\text{if 2 per } \$211,200)$$

(No Fee for Opening & Closing)

Total \$710,419.16

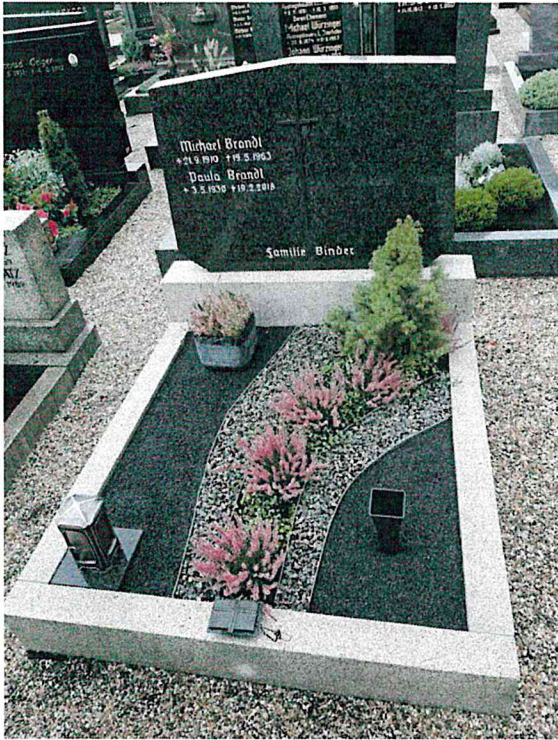

“Oleander Lane”

Expansion of Kern Cemetery

352 Columbarium \$378,131.16

200 Plots \$1,500,000

Total = \$1,878,131.16

Additional Income - Plots & Niches Totals

Administration Total based on 2 = \$331,200

Opening & Closing based on 2 = \$800,000

(Niches does not currently have opening & closing fee)

Installation Fee for Liner based on 2 per plot – 2 x \$263 = \$526

\$526 x 200 = \$105,200

Endowment based on 2 = \$278,288

Benches per plot 200 = \$500,000

NOTE: Much needed improvement to make this area more appealing would be to replace existing fence and it can be done in phases the Sonora side being the first phase

(Quote for 7 foot Iron fence all around Kern Cemetery with Iron Gates – 1 quote so far working on more – Spence Fence \$888,040) – yes verified by City to do 7 foot fence no permit needed



"Oleander Lane"
Tall Stone Row



← 5 →

Over
← 5 →

Extra Space can move Fence
Back But not heeded

Google Maps 1070 E Sonora Ave

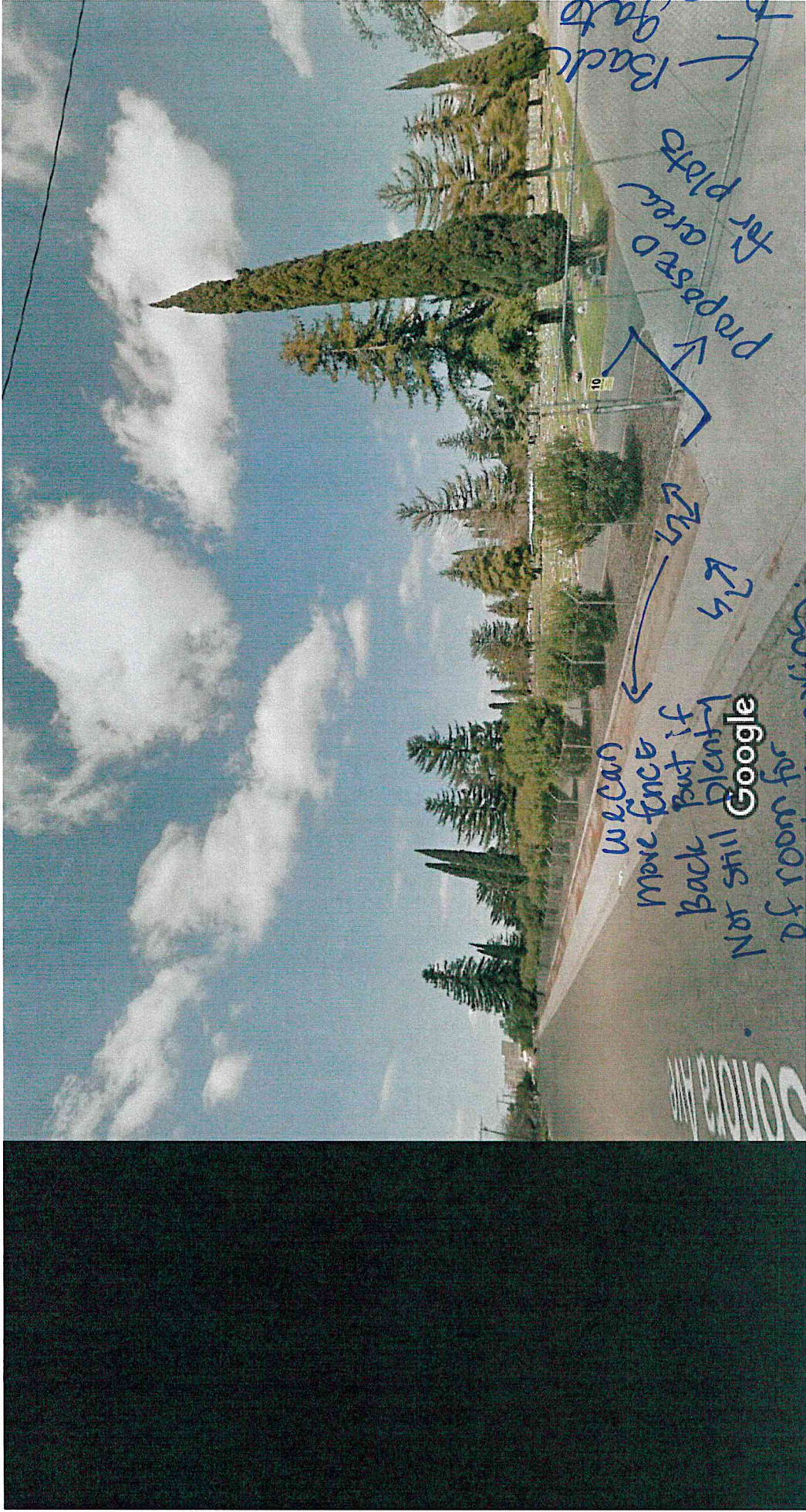

Image capture: Mar 2019 © 2022 Google

Tulare, California

Google

Street View - Mar 2019

Google Maps 998 E Sonora Ave

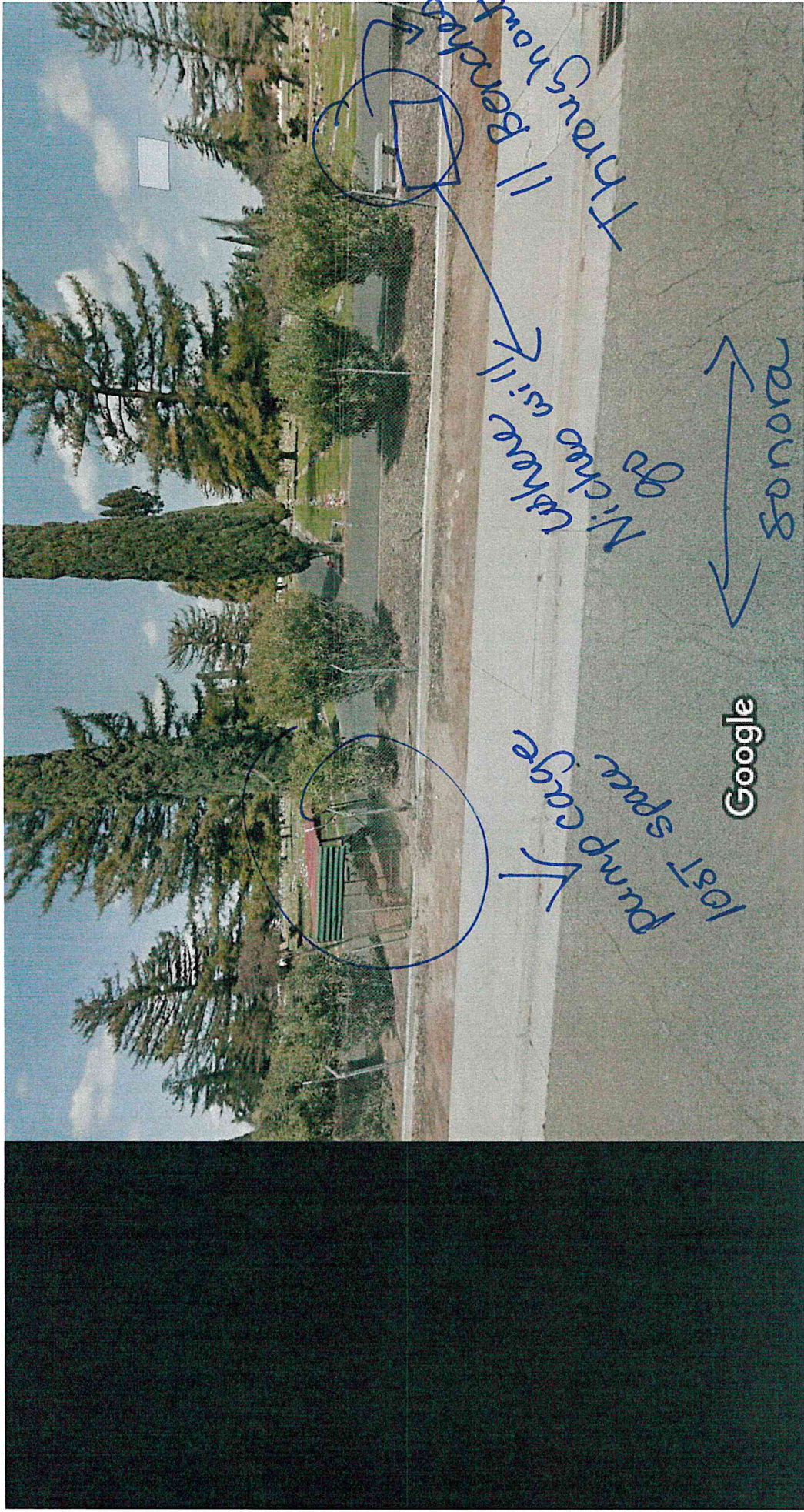

Image capture: Mar 2019 © 2022 Google

Tulare, California

Google

Street View - Mar 2019

Google Maps 955 E Sonora Ave

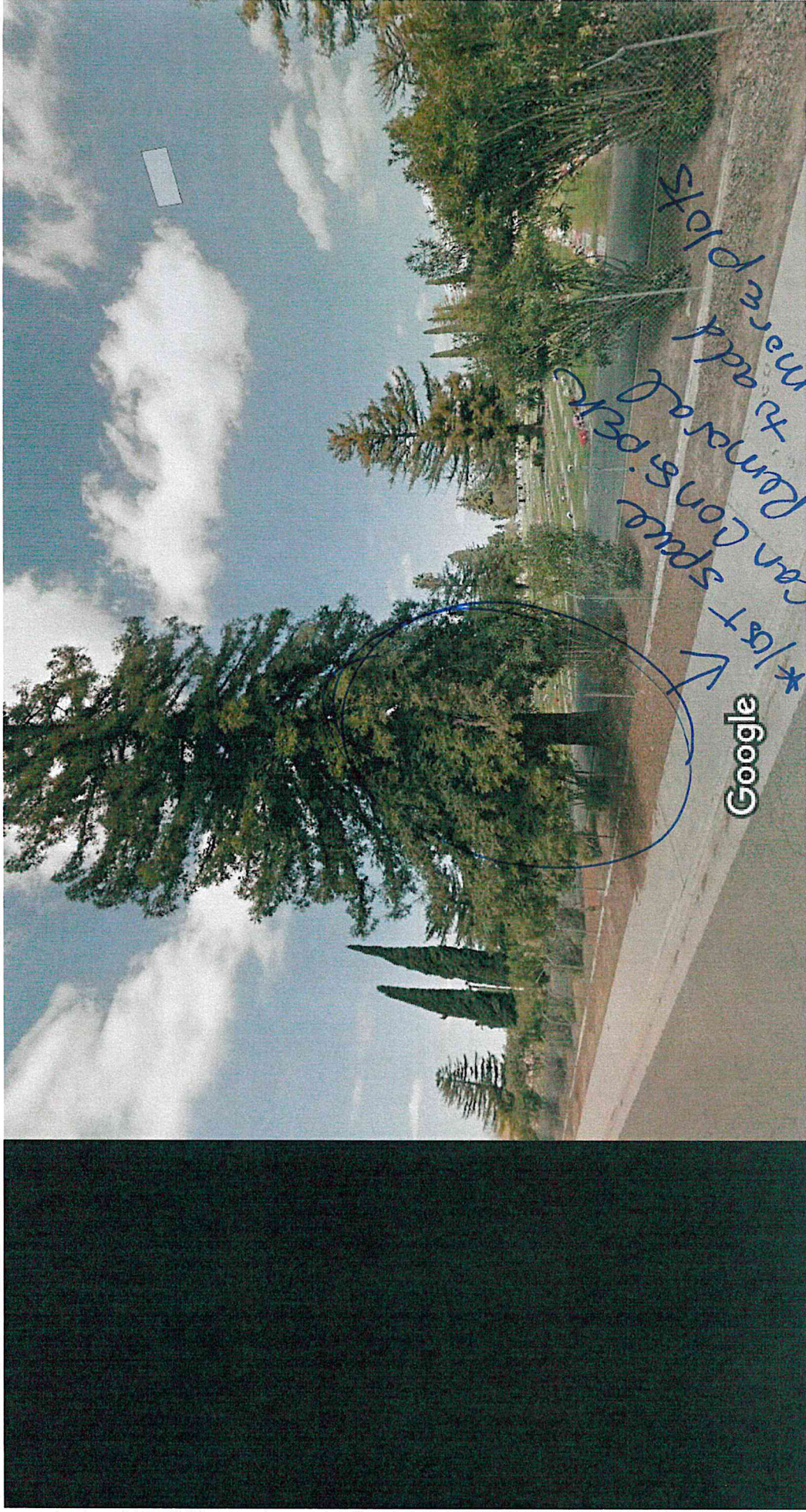
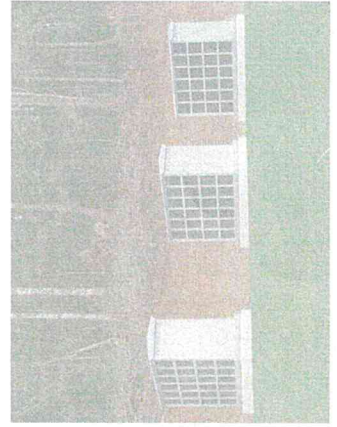

Image capture: Mar 2019 © 2022 Google

Tulare, California

Google

Street View - Mar 2019



2-SIDES EACH SIDE $16 \times 2 = 32$ Niches

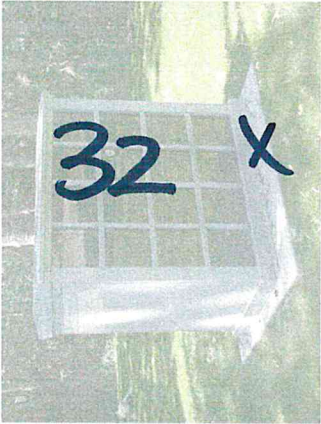

Clara Bernardo

From: Doug Stilnovich
Sent: Wednesday, January 5, 2022 11:11 AM
To: Clara Bernardo
Subject: Re: QUOTE
Attachments: PC-F-3402.pdf

\$4,953 each x 11 = \$54,483
Freight estimated \$19,850

11 units \$74,433 delivered but not installed

Installation
\$6,500 depending on crane accessibility

Total delivered and installed on customer supplied foundations
\$80,993

Sent from my iPhone

On Jan 5, 2022, at 10:43 AM, Clara Bernardo <clara@tularecemetery.net> wrote:

Morning wondering if you had a chance to go over the cost

Clara L. Bernardo
District Manager



**900 E. Kern Avenue –
Tulare, CA 93274
(559) 686-5544
www.tularecemetery.net**

- ① 61 1/2*35*5 1pc
- ② 61 1/2*31*4 1pc
- ③ 29*3*52 1/2 2pcs
- ④ 54 1/2*2*26 1/4 2pcs
- ⑤ 53 1/2*13 1/2*1 1/2 6pcs
- ⑥ 13 1/2*2*12 16pcs
- ⑦ 13 1/2*1 1/2*12 8pcs
- ⑧ 12 1/2*12*3/4 32pcs

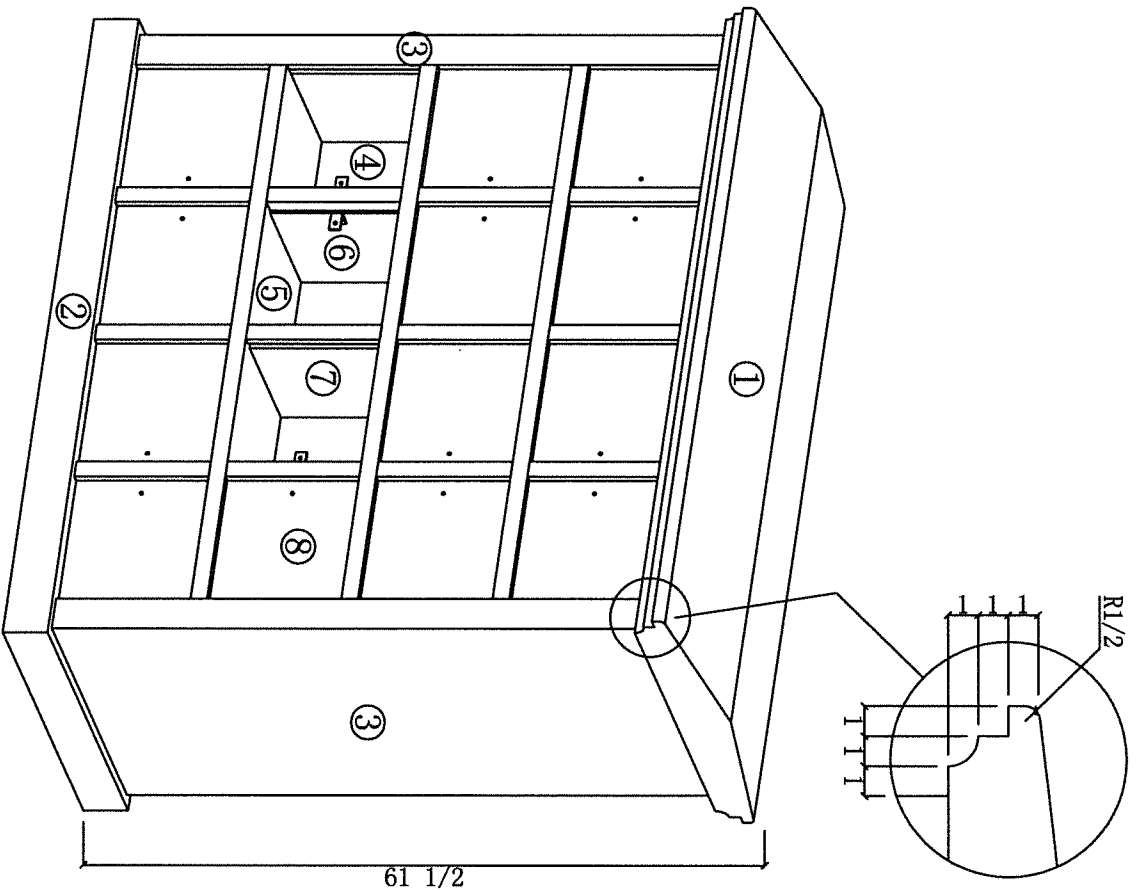
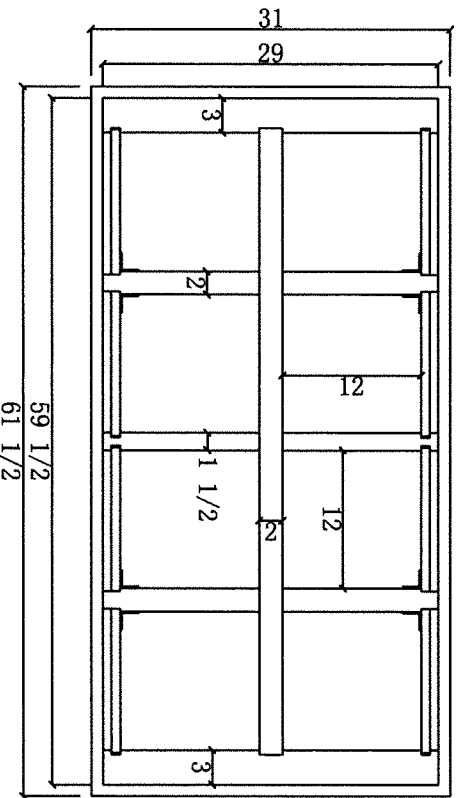

Premier Columbaria

Secure Slide Door™ with single rosette closure Copyright 2022.
Premier Columbaria LLC. All rights reserved.

Drawing Name		Revision	
Drawing NO.	PC-F-3402	Date	01-05-22
Units	INCH (")	Sheet NO.	1 OF 1

Spence Fence Company Enterprises

Estimate

1145 No. Miller Park Ct.
Visalia, CA 93291

Phone# (559) 651-2889 Fax# (559) 651-2890

License# 987483

Date	Estimate #
12/17/2021	11381

Name / Address
TULARE CEMETARY 900 E. KERN TULARE, CA 93274

Terms & Conditions

1. Owner is to be present when the crew arrives.
2. Owner is to verify the location of the fence to be removed & or installed.
3. Owner is required to inspect the job when completed.
4. Owner is required to pay the invoice in full to the crew leader on site.
5. Warranty: One year on workmanship, no warranty on wood products after the job is inspected, due to wood being exposed to the natural elements. (water, sun, etc.)
6. Spence Fence Company Enterprises is not responsible for underground pipes, wire, cables, gas lines etc. USA will be called by Spence Fence Company Enterprises before starting the job if it is located in the front of the house or utility easement.
7. Owner is to clear a two foot pathway along the fence line.

Description	Qty.	Rate	Contact
			Total
INSTALL APPROXIMATELY 5060' OF 7' TALL BLACK ARISTOCRAT STYLE IRON FENCE		813,040.00	813,040.00
TEAR OUT AND HAUL			
MATERIALS			
4" GATE POST			
2 1/2" POST			
1 1/2 RAILS			
3/4" PICKETS			
OPTION FOR 3- 20' X 7' TALL ROLL GATES & 2- 16' X 7' TALL ROLL GATES, CONCRETE AND V-TRACK IS AN ADDITIONAL \$ 15,000.00 EACH GATE TOTAL ADDITIONAL COST FOR THE 5 GATES WOULD BE \$ 75,000.00			
JOB: 900 E KERN AVE. TULARE, CA (SOUTH TULARE CEMETARY)			
JOB: IS PREVAILING WAGE			

Signature _____	Total	\$813,040.00
-----------------	--------------	---------------------

Notice to Owner

Under the Mechanics lien law, any contractor, subcontractor, laborer, materialman or other person who helps to improve your property and is not paid for his labor, services or material, has a right to enforce his claim against your property. Under the law, you may protect yourself against such claims by filing, before commencing such work or improvement, an original contract for the work of improvement or a modification thereof, in the office of the county recorder of county where the property is situated and requiring that a contractor's payment bond be recorded in such office. Said bond shall be in an amount not less than fifty percent (50%) of the contract price and shall, in addition to any conditions for the performance of the contract, be conditioned for the payment in full of the claims of all persons furnishing labor, services, equipment or materials for the work described in said contract."

**** WE ACCEPT ALL MAJOR CREDIT CARDS ****

Estimated price includes material, and labor to complete job as stated above, unless otherwise noted. Price may be adjusted to actual measured footage completed. Due to varying material cost, this estimate is valid 20 days from date.

CALIFORNIA ASSOCIATION OF PUBLIC CEMETERIES
64th ANNUAL CONFERENCE
 March 10 - 12, 2022

REGISTRATION

Name _____ Position _____
 Guest Name _____
 District _____
 Address _____
 City/State/Zip _____

First time attendee at CAPC event, Yes No
 Please complete separate registration for each attendee and return with
 payment no later than Friday, February 18, 2022. No Refunds will be made on
 cancellations received in the CAPC office after Friday, February 18, 2022.

Registration Fee (For One Person): \$ 449.00
 Registration for Non Member: \$549.00

Includes:

- Thursday Evening Hospitality
- Friday Plated Lunch (Special: _____ Vegetarian Lunch)
- Friday Plated Dinner (Special: _____ Vegetarian Dinner)
- Saturday Plated Lunch (Special: _____ Vegetarian Lunch)
- Saturday Plated Awards Dinner (Special: _____ Vegetarian Dinner)

(*See meal menu below)

Guest Friday Plated Lunch @ \$ 39.00 each \$ _____
 (Special: _____ Vegetarian Lunch)
 *Smoked Turkey Breast Sandwich
 Guest Friday Plated Dinner @ \$ 69.00 each \$ _____
 (Special: _____ Vegetarian Dinner)
 *Artichoke Rosemary Chicken Breast
 Guest Saturday Plated Lunch @ \$ 43.00 each \$ _____
 (Special: _____ Vegetarian Lunch)
 *Cobb Salad with Grilled Chicken
 Guest Saturday Plated Awards Dinner @ \$ 74.00 each \$ _____
 (Special: _____ Vegetarian Dinner)
 *Sliced Black Angus Tri-Tip with Peppercorn

Hospitality Co-Sponsor (Optional)
 \$ 50.00 to \$ 99.00 Silver
 \$ 100.00 to \$ 199.00 Gold
 \$ 200 and up Platinum

Total Enclosed: \$ _____

Send completed registration and check to:

California Association of Public Cemeteries Phone: 951-925-1111
 P.O. Box 119 Toll Free (CA) 888-344-9858
 San Jacinto, CA 92581 Fax: 951-652-3643

Scholarship applications from CAPC member districts are being accepted until
 January 14, 2022 for Scholarships to attend the conference. Contact CAPC.

California Association
 of
 Public Cemeteries

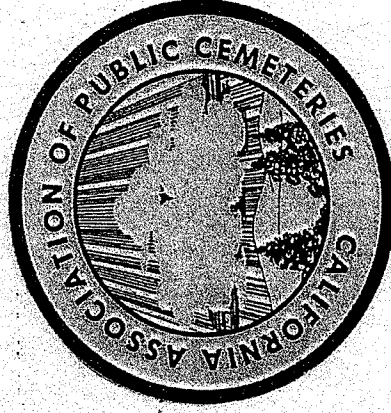

64th
 Annual Conference
 March 10 - 12, 2022

Embassy Suites
 Monterey Bay
 1441 Canyon Del Rey
 Seaside, CA 93955

CAPC CONFERENCE HIGHLIGHTS

Who should attend: Trustees, Managers, Secretaries and employees interested in increasing their knowledge of public cemetery district governance, operation and administration.

Featuring:

- **Policy & Procedures:** The presentation will explore just what policies and procedures are, the difference between them, why they are needed, and how to use them. We will discuss a few drafting tips, the need to continually review and update, and a few policies and procedures that you are required to have and several you might want to have. This program is intended to be an interactive discussion of policies, procedures, rules, and regulations, so bring your questions, concerns and suggestions and be prepared to participate.
- **Ethics Training ABI234:** Required training for Trustees & designated Staff Members.
- **The Sustainable Groundwater Management Act:** To meter of not to meter, that is the question - along with a discussion on water restrictions.
- **Going Green with Electric Equipment:** What will be needed in order to comply with the changing laws & what are your options.
- **State Legislation:** Hear the up-to-date legislative information that affects public cemetery districts.
- **Problem Solving:** Trustees, Managers/Secretaries Workshops provide the opportunity to share information and ask questions about problems that are common to other districts.
- **Exhibitors of cemetery:** Equipment, supplies, computer programs, liability/property & workers' compensation insurance and much more.
- **Door Prizes:** Traditionally, Districts bring door prizes that are common to their area of the state. These are distributed to attendees at the evening events.
- **Grand Door Prize:** A drawing for the Grand Door Prize will be held at the end of the conference programs on Saturday afternoon. You have to be present to win.

“AND MUCH MORE”

Special Events:

Thursday, March 10, 2022:

- **CAPC Annual Golf Tournament & Golf Awards:**
Laguna Seca Golf Ranch
- **Hospitality:** Don't miss the Thursday evening hospitality from 5:30 p.m. - 7:00 p.m. Co-Sponsored by CAPC, Participating Districts and Exhibitors. There will be a tempting variety of hors d'oeuvres, and fellowship with other cemeterians from districts throughout the state.
- Districts and Exhibitors are encouraged to help make this another successful event. All co-sponsors funds collected will be used for the Thursday evening hospitality.
- **Recognition for Hospitality Co-Sponsors:**
 - \$ 50.00 to \$ 99.00 Silver
 - \$ 100.00 to \$ 199.00 Gold
 - Over \$ 199.00 Platinum

Friday, March 11, 2022:

Exhibitor's Lunch:

Mel Lewis Memorial Awards

Join us for Dinner:

The Killer Dueling Pianos

Honorary Membership Awards

Saturday, March 12, 2022:

Saturday evening will be our Annual Awards Dinner which will include announcing the selection of the President's Award, Trustee & Manager of the Year, Cemeterian of the Year and Ruben Siemens-Wayne Byington Memorial Awards.

“Donated Door Prizes

are encouraged and appreciated”

Drawings for door prizes donated by Districts and Exhibitors will be held at

Friday and Saturday evening events.

Conference Agenda

Thursday, March 10, 2022

- 6:00-9:00 a.m. Cooked-to-Order breakfast for registered Hotel Guests
- 8:00 a.m. Exhibitors set-up displays
- 8:00 a.m. Annual Golf Tournament/Awards:
Laguna Seca Golf Ranch
- 4:30-6:30 p.m. Registration Desk Open
- 5:30-7:00 p.m. Hospitality in Exhibitor's Showroom

Friday, March 11, 2022

- 6:00-9:00 a.m. Cooked-to-Order breakfast for registered Hotel Guests
- 7:15 a.m. Registration Desk Opens
- 8:00 a.m. Call To Order - Pledge of Allegiance
Welcome/Program Introductions
- 8:15 a.m. Featured Cemetery: Tehachapi Cemetery District
Presented by Danny Brown, CSDM, District Manager
- 8:30 a.m. Policy & Procedures:
Presented by Bob Hunt of Hunt Law Offices
- 10:30 a.m. Break - Visit Exhibits
- 11:00 a.m. Ethics Training AB1234:
Presented by Karen O'Neil from Kirk & Simas
- Noon Lunch: Exhibitors Introduction/Mel Lewis Memorial Awards
"Donation Drawing"
- 1:20 p.m. Ethics Training AB1234:
Presented by Karen O'Neil from Kirk & Simas
- 2:30 p.m. Adjourn - Visit Exhibits - Cash Door Prize
- 6:00 p.m. Dinner:
The Killer Dueling Pianos
"Honorary Membership Awards"

Saturday, March 12, 2022

- 7:00-10:30 a.m. Cooked-to-Order breakfast for registered Hotel Guests
- 7:30 a.m. Registration Desk Opens
- 8:00 a.m. Combined Group Discussion:
Trustees-Managers/Secretaries
Break: Visit Exhibits
- 10:00 a.m. Exhibitor's Ticket Drawing
- 10:50 a.m. CSDA Legislation Update:
Presented by Anthony Tannehill, Legislative Representative
- Noon Lunch
- 1:20 p.m. "Donation Drawing"
- 1:30 p.m. Annual Meeting - Board of Directors Election
- 2:30 p.m. The Sustainable Groundwater Management Act/Going Green
with Electric Equipment: Presented by
Michael Ott, Trustee, North County Cemetery District and
Barry Braun, Trustee, Kern County Cemetery District No. 1
- 3:30 p.m. Adjourn "Grand Prize Drawing"
- 4:00 p.m. Board of Directors Meeting-Election of Officers
- 6:00 p.m. Annual Awards Dinner:
"Presidents' Award"
"Manager of the Year" / "Trustee of the Year"
"Cemeterian of the Year"
"Ruhren Siemens-Wayne Robinson Memorial Award"

CONFERENCE LOCATION

Embassy Suites Monterey Bay 1441 Canyon Del Rey Seaside, California 93955

Make your hotel reservations directly to the Embassy Suites Hotel. The hotel is charging CAPC guests \$ 221.90 for a Standard King Bed Suite or \$ 244.34 for a Standard Double Beds Suite per night. (Tax included)

For Reservations Call (800) 362-2779 or the hotel directly at (831) 393-1115 mention group code CPC.

The hotel is holding a block of rooms for us until Monday, February 7, 2022.

Hotel check-in time is 4:00 p.m. and check-out time is 11:00 a.m. Hotel room rate includes cooked-to-order breakfast each day. Free standard guestroom Wi-Fi. Self parking is \$ 6.00 per night.

For additional information call the CAPC office at (951) 925-1111 or toll free (888) 344-9858.

MAKE YOUR HOTEL RESERVATIONS TODAY!

Directions to Embassy Suites Hotel

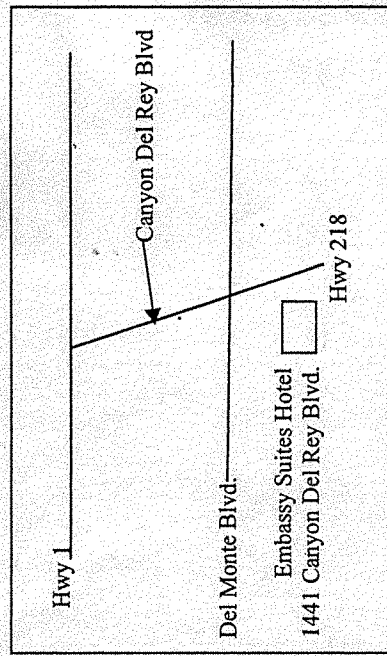

Hardship Policy Addressing Capacity of Graves

The Tulare Public Cemetery District has established that up to Six (6) Internments can occupy a Full Size Grave and Four (4) per Half Grave. In previous years up to Four (4) Internments were approved to occupy a Full Size Grave and Two (2) per Half Grave. Due to this situation in order to accommodate the updated Internment count per Full Size Grave and Half Grave then at times it may be necessary to disinter a cremation to accommodate full capacity per Grave.

Consent must be given by the next of kin and owner of the grave before any disinterment and reinternment can be completed by the Tulare Public Cemetery. After consent and proper forms have been completed by next of kin The Tulare Public Cemetery will disinter the cremation that needs to be repositioned and intern immediately after the new burial has been positioned in the grave. This will be necessary at times for burials that happened in years past which were only able to accommodate Four (4) Internments in Full Size Graves and Two (2) in Half Graves. No Fee will be charged for disinterment's which are done solely to accommodate more internments in one single plot.

The Cemetery District may occasionally receive a request for interred human remains to be disinterred and reinterred within the cemetery or removed from the cemetery. Before the Tulare Cemetery proceeds to honor a disinterment request, it should be assured that all required parties have provided authorization or that disinterment has been ordered by a Court of Law.

Disinterment procedures should protect the wishes and intent of the decedent and the respective interests of the interment right owners. The next of kin of the decedent, cemetery authorities, and the general public. The Tulare Public Cemetery should establish procedures to protect the health and safety of those involved in the disinterment process.

Adopted by the Board of the Tulare Public Cemetery District on ____/____/2022

Signed:

Chair, Board of Trustees

Clara Bernardo

From: Andy Hinojosa
Sent: Thursday, December 30, 2021 2:18 PM
To: Clara Bernardo
Cc: Steve Presant
Subject: Courtesy Credit for Tulare Public Cemetery District / Meeting with Vicki Gilson

Hi Clara and Tammy,
I received a letter from Vicki Gilson requesting that I reverse the \$75 charge I billed for the time I spent discussing with her accounting items related to the District in November. Because of her request, please issue a courtesy credit to the District's account for the \$75. The credit should appear on the District's December 2021 bill.

Thank you!

Andy Hinojosa
Certified Public Accountant

December 28, 2021

Andy Hinojosa, CPA

Dear Andy,

It has been brought to my attention that you billed the Tulare Public Cemetery District for a conversation we had on October 16, 2021.

I visited your office on the afternoon of October 16 and asked to see you, identifying myself as Vicki Gilson to your receptionist. You came out to greet me and said that you were fairly busy, but asked me the reason for my visit. I said I had a few questions about the Cemetery and you invited me into your office. I never identified myself as a Board member and at no time did you inform me that your time would be billed.

I told you that I had viewed a video of the last Audit Committee meeting and wanted to clarify a few of the items discussed, namely payroll and monthly financial reporting and your role in the processes. You printed out a copy of your Agreement with the Cemetery, which was the same Agreement the Cemetery Board approved at an earlier meeting. You stated that you had not in fact been preparing payroll and payroll returns, that a company called Paychex had been preparing the payroll since May 2021. You stated that you are assisting with the financial information and monthly statements.

I informed you that the Audit Committee did not approve the August and September 2021 financial reports and that the discussion during the recorded meeting referenced concerns with you. Steve Presant said that you had been busy and couldn't meet, and Clara expressed concerns with your entry of items into Quickbooks. You advised me that you reserved every Wednesday afternoon for the Cemetery and that you had been waiting to hear from Steve Presant. When I commented that 4 hours every Wednesday at your billing rate of \$150/hour would be \$600 a week, or \$2400 a month, you stated that there was a lot of work to be done. You stated that Phyllis was new to the system and that there are "lots of accounting errors." You stated that Clara had "some experience."

You discussed overall accounting concepts with me, including "cash" or "accrual" basis, timing of information, and materiality, and your intent to teach and coordinate these concepts into the Cemetery process.

I appreciate the time you spent with me and your professional and friendly manner. I was really thankful that you provided the information to me as a member of the Tulare community and were able to answer some of my concerns. As a fee was never discussed or referenced, I would ask you to reverse the \$75 fee from the Cemetery's invoice.

Sincerely,

Vicki Gilson

Cc: Tulare Public Cemetery

Subject: ERTC SERVICE-87 14118541

Hello,

Please find the attached Covid -19 Wage Reports and related calculations documenting the calculations for the ERTC for the tax period listed below.

What's next?

Please review the attached reports in detail to ensure accuracy – we will move forward with processing your ERTC wages, amended returns and filing to the IRS per the attached report on **12/21/2021 unless Client replies before this date (This also includes more time to review).**

- Once remitted to the IRS they will process the amended return.
- Upon the IRS processing the amendment and as long as your account is in good standing - free from any outstanding balances, a refund will be issued for the amount of the ERTC credits.

ERTC Summary of Quarters		
Quarter	Credit	Reviewed
2020 Q2	-	
2020 Q3	-	
2020 Q4	-	
2021 Q1	59,770.24	X
2021 Q2	63,799.20	X
2021 Q3	-	
2021 Q4	-	

Your next invoice will have fees in the amount of \$3000.

The total Employee Retention Tax Credit we have calculated based on the information provided in the questionnaire and our payroll records is \$123,569.439.

ERTC SERVICE REPRESENTATIVE

PAYCHEX

HR | Payroll | Benefits | Insurance

The Power of Simplicity®



Employee Retention Credit

Delays in Employer Credit Advance Payments



Expect payment delays until late January 2022 for Form 7200, Advance Payment of Employer Credits. Taxpayers may continue to file Forms 7200 by facsimile until January 31, 2022 and their applicable employment tax returns by the required due date. Thank you for your patience during our annual system update.

This Page is Not Current



See instead: [New law extends coronavirus tax credit for employers who keep workers on payroll](#). The Taxpayer Certainty and Disaster Tax Relief Act of 2020, enacted December 27, 2020, amended and extended the employee retention credit (and the availability of certain advance payments of the tax credits) under section 2301 of the CARES Act.

Check back later for updates to this page.

Employee Retention Credit Limitation

The Infrastructure Investment and Jobs Act, enacted on November 15, 2021, amended section 3134 of the Internal Revenue Code to limit the Employee Retention Credit only to wages paid before October 1, 2021, unless the employer is a recovery startup business.

For more information see: [IRS issues guidance regarding the retroactive termination of the Employee Retention Credit.](#)

The Employee Retention Credit is a refundable tax credit against certain employment taxes equal to 50% of the qualified wages an eligible employer pays to employees after March 12, 2020, and before January 1, 2021. Eligible employers can get immediate access to the credit by reducing employment tax deposits they are otherwise required to make. Also, if the employer's employment tax deposits are not sufficient to cover the credit, the employer may get an advance payment from the IRS.

For each employee, wages (including certain health plan costs) up to \$10,000 can be counted to determine the amount of the 50% credit. Because this credit can apply to wages already paid after March 12, 2020, many struggling employers can get access to this credit by reducing upcoming deposits or requesting an advance credit on [Form 7200, Advance of Employer Credits Due To COVID-19.](#)

Employers, including tax-exempt organizations, are eligible for the credit if they operate a trade or business during calendar year 2020 and experience either:

1. the full or partial suspension of the operation of their trade or business during any calendar quarter because of governmental orders limiting commerce, travel or group meetings due to COVID-19, or
2. a significant decline in gross receipts.

A significant decline in gross receipts begins:

- on the first day of the first calendar quarter of 2020
- for which an employer's gross receipts are less than 50% of its gross receipts
- for the same calendar quarter in 2019.

The significant decline in gross receipts ends:

- on the first day of the first calendar quarter following the calendar quarter
- in which gross receipts are more than of 80% of its gross receipts
- for the same calendar quarter in 2019.

The credit applies to qualified wages (including certain health plan expenses) paid during this period or any calendar quarter in which operations were suspended.

Qualified wages

The definition of qualified wages depends on how many employees an eligible employer has.

If an employer averaged more than 100 full-time employees during 2019, qualified wages are generally those wages, including certain health care costs, (up to \$10,000 per employee) paid to employees that are not providing services because operations were suspended or due to the decline in gross receipts. These employers can only count wages up to the amount that the employee would have been paid for working an equivalent duration during the 30 days immediately preceding the period of economic hardship.

If an employer averaged 100 or fewer full-time employees during 2019, qualified wages are those wages, including health care costs, (up to \$10,000 per employee) paid to any employee during the period operations were suspended or the period of the decline in gross receipts, regardless of whether or not its employees are providing services.

Impact of other credit and relief provisions

An eligible employer's ability to claim the Employee Retention Credit is impacted by other credit and relief provisions as follows:

- If an employer receives a Small Business Interruption Loan under the Paycheck Protection Program, authorized under the CARES Act, then the employer is not eligible for the Employee Retention Credit.
- Wages for this credit do not include wages for which the employer received a tax credit for paid sick and family leave under the Families First Coronavirus Response Act.
- Wages counted for this credit can't be counted for the credit for paid family and medical leave under section 45S of the Internal Revenue Code.
- Employees are not counted for this credit if the employer is allowed a Work Opportunity Tax Credit under section 51 of the Internal Revenue Code for the employee.

Claiming the credit

In order to claim the new Employee Retention Credit, eligible employers will report their total qualified wages and the related health insurance costs for each quarter on their quarterly employment tax returns, which will be Form 941 for most employers, beginning with the second quarter. The credit is taken against the employer's share of Social Security tax but the excess is refundable under normal procedures.

In anticipation of claiming the credit, employers can retain a corresponding amount of the employment taxes that otherwise would have been deposited, including federal income tax withholding, the employees' share of Social Security and Medicare taxes, and the employer's share of Social Security and Medicare taxes for all employees, up to the

amount of the credit, without penalty, taking into account any reduction for deposits in anticipation of the paid sick and family leave credit provided in the [Families First Coronavirus Response Act](#)  [PDF](#).

Eligible employers can also request an advance of the Employee Retention Credit by submitting Form 7200.

More Information

- [COVID-19-Related Tax Credits for Required Paid Leave Provided by Small and Midsize Businesses FAQs](#)
- [Employee Retention Credit Under the CARES Act FAQs](#)
- [Paycheck Protection Program](#) 
- [COVID Tax Tip 2020-47, Common errors to avoid when filing for advance payment of employer credits](#)

Page Last Reviewed or Updated: 27-Dec-2021